

DO NOT SCALE DRAWING WORK TO FIGURES

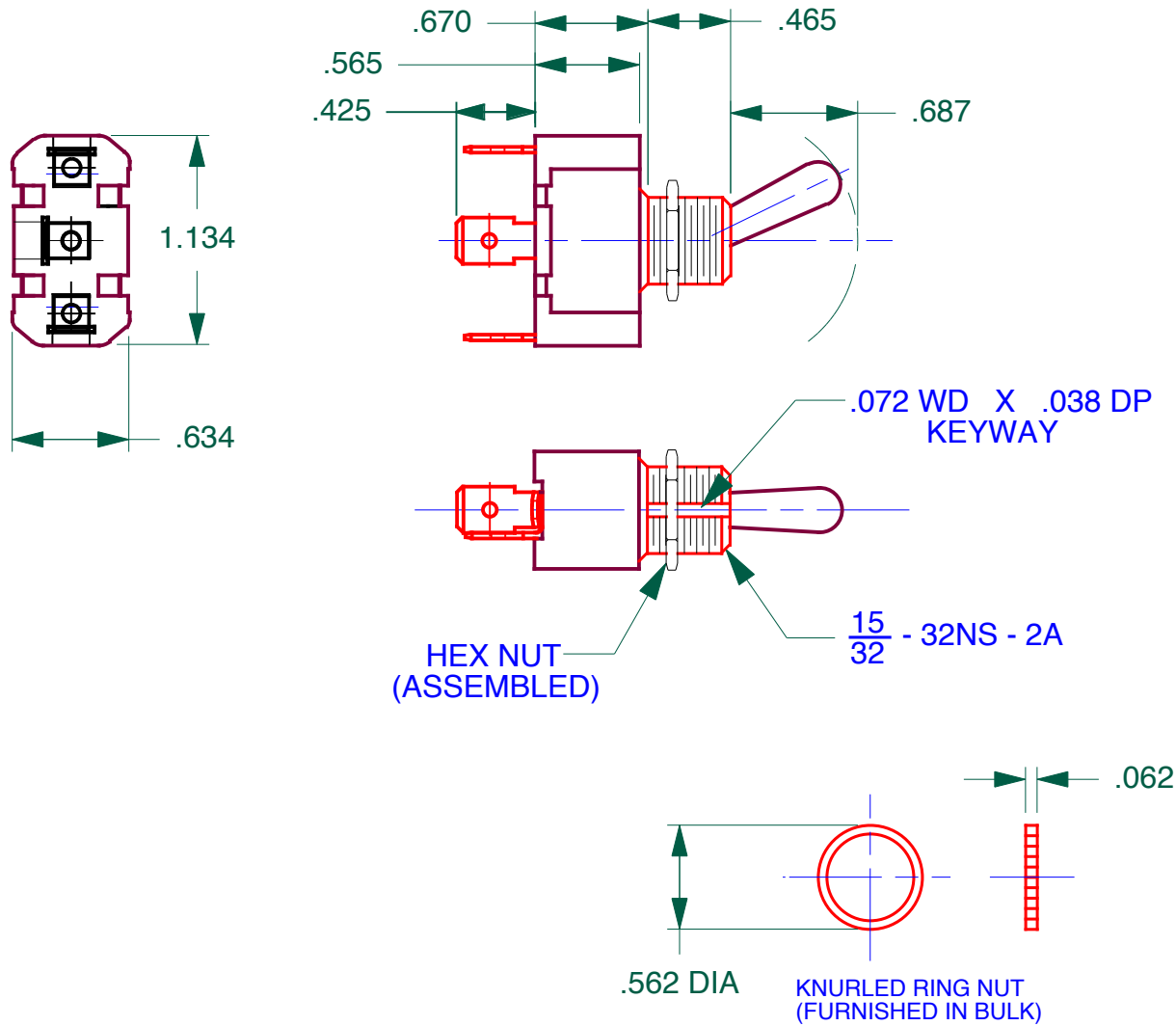

DWG NO. 2FC53-73/TABS		REV.
LET	REVISIONS	DATE

<u>RATING</u>	UL & CSA
10A	<u>250</u> VAC
15A	125VAC
3/4HP	125- <u>250</u> VAC

OPERATES:
POSITIONS OF TOGGLE

<u>UP</u> <u>ON</u>	<u>CENTER</u> <u>OFF</u>	<u>DOWN</u> <u>ON</u>
2 - 3		1 - 2

- NOTES:
- KEYWAY INDICATES DOWN POSITION
 - TOGGLE, BUSHING, RING NUT HEX NUT ARE NICKEL PLATED BRASS
 - .250 TAB TERMINALS

DIMENSIONS SUBJECT TO CHANGE WITHOUT NOTICE

FINISH

CARLINGSWITCH, INC.
PLAINVILLE, CT

PROPRIETARY NOTE:

NOTICE TO ALL PERSONS RECEIVING THIS DRAWING. THIS DOCUMENT IS THE PROPERTY OF CARLINGSWITCH, INC. AND IS NOT TO BE DISCLOSED, REPRODUCED IN WHOLE OR IN PART OR USED FOR MANUFACTURING PURPOSES BY ANYONE WITHOUT THE CONSENT OF CARLINGSWITCH, INC.

UNSPECIFIED TOLERANCES

FRAC. ±1/64 X.XXX ±.015
ANGLES ±1°

PROJECTIONS



DIMENSIONS
IN [mm]

TOOL NO.	REV
DR BY KRAMARZ	DATE 3-24-14
CHK BY	DATE
APPD BY	DATE

TITLE F SERIES TOGGLE SWITCH		REV.
SIZE A	DWG NO. 2FC53-73/TABS	
USED ON	SCALE: NONE	SHT 1 OF 1